

# Inorax-ST Network Cabinet



## Inorax-ST Network Cabinet

Inorax-ST, a cost effective network rack cabinet system fulfills high density cabling and data center requirements. With its modular structure, a practical option for your future plans. Offers advanced fiber and copper cable management options; helps simplify cable installation and maintenance while providing maximum cable capacity for your high-density cabling requirements. A wide range of cable management accessories is available to ensure perfect management of copper, fiber cables and 19" equipment. Flat-pack option enables savings up to 60% in the transport cost and warehouse space.

### Technical Features

<b>Material</b>	1-1,2-1,5-2mm Steel
<b>Color</b>	RAL 7035 or RAL 9005
<b>Compliance</b>	RoHS, UL Certified
<b>Packaging</b>	Assembled or unassembled
<b>Maximum Static Load</b>	Up to 1500 kg.
<b>Finish</b>	Doors, side panels, top and bottom covers Electrostatic Powder Paint, 19" mounting rails: Zinc-plated

### Standard Configuration:

- Front door with safety glass
- Solid Side Panels with cylindrical locks and latches
- Solid Rear Panel with cylindrical locks
- Internal top sheet with 3 cable entries for 800 width, 1 cable entry for 600 width racks and fan cut-outs
- 2 Pairs of depth adjustable heavy duty 19" Mounting Rails
- 2 Pairs of Adjustable Feet
- Front Door with swing-handle single point lock
- Bottom cover with 3 cable entries for 800 width, 1 cable entry for 600 width racks



**CERTIFIED**



Front View



Front View Open



3/4 View



Side View

# Inorax-ST Network Cabinet

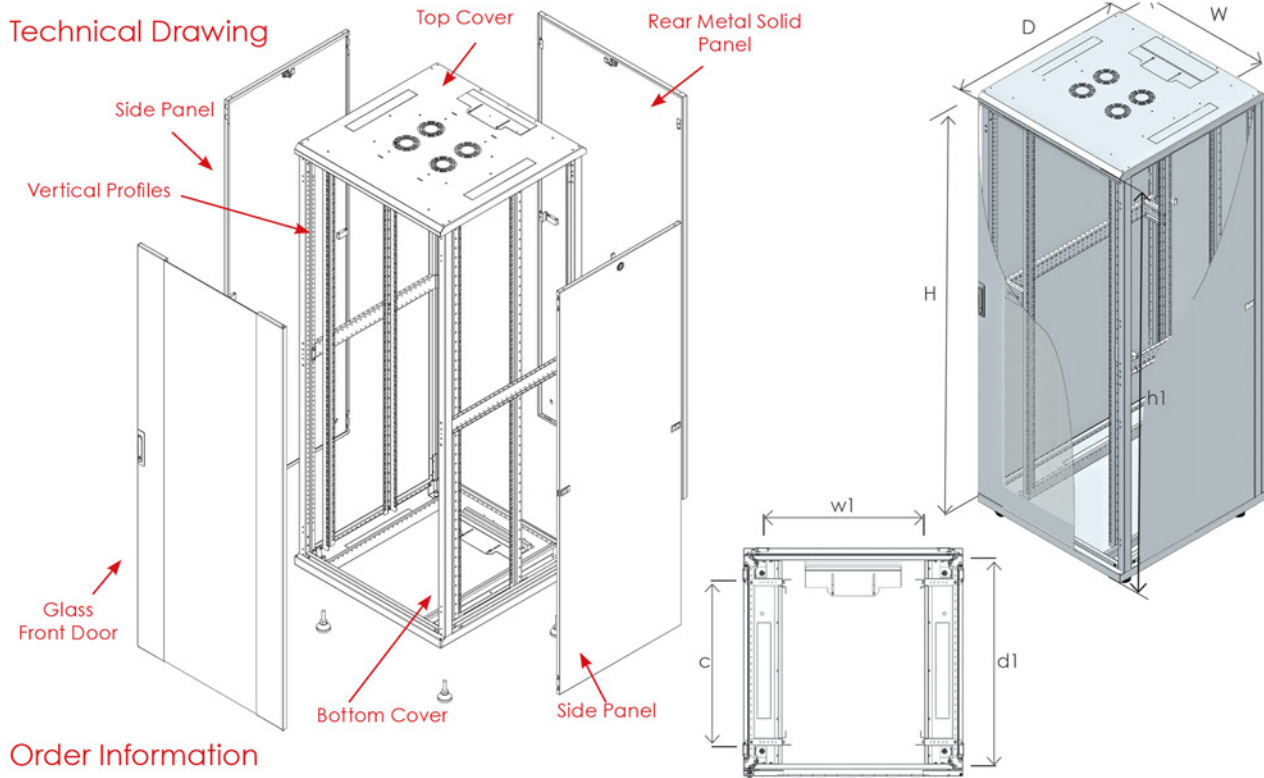

## Order Information

Height U	Outer Width (W) mm	Outer Depth (D) mm	Outer Height (H) mm	Inner Width (w1) mm	Inner Depth (d1) mm	Inner Height (h1) mm	19" Rails Adjustable Depth Range (c)	Weight kg	Part No
16U	600	600	878	503	550	718	123 - 373	52,8	CSN-X-1666A
22U	600	600	1144	503	550	984	123 - 373	62,2	CSN-X-2266A
22U	600	800	1144	503	750	984	123 - 573	70,7	CSN-X-2268A
26U	600	600	1322	503	550	1162	123 - 373	68,5	CSN-X-2666A
26U	600	800	1322	503	750	1162	123 - 573	77,6	CSN-X-2668A
26U	800	800	1322	703	750	1162	123 - 573	91,6	CSN-X-2688A
32U	600	600	1588	503	550	1428	123 - 373	77,9	CSN-X-3266A
32U	600	800	1588	503	750	1428	123 - 573	88,0	CSN-X-3268A
32U	800	800	1588	703	750	1428	123 - 573	103,2	CSN-X-3288A
36U	600	600	1766	503	550	1607	123 - 373	84,2	CSN-X-3666A
36U	600	800	1766	503	750	1607	123 - 573	95,0	CSN-X-3668A
36U	800	800	1766	703	750	1607	123 - 573	110,0	CSN-X-3688A
39U	800	800	1900	703	750	1740	123 - 573	115,5	CSN-X-3988A
42U	600	600	2033	503	550	1873	123 - 373	93,6	CSN-X-4266A
42U	600	800	2033	503	750	1873	123 - 573	105,4	CSN-X-4268A
42U	600	1000	2033	503	950	1873	123 - 773	113,9	CSN-X-4260A
42U	800	800	2033	703	750	1873	123 - 573	121,3	CSN-X-4288A
42U	800	1000	2033	703	950	1873	123 - 773	133,5	CSN-X-4280A
47U	600	600	2255	503	550	2095	123 - 373	101,5	CSN-X-4766A
47U	600	800	2255	503	750	2095	123 - 573	114,0	CSN-X-4768A
47U	600	1000	2255	503	950	2095	123 - 773	123,2	CSN-X-4760A
47U	800	800	2255	703	750	2095	123 - 573	131,0	CSN-X-4788A
47U	800	1000	2255	703	950	2095	123 - 773	144,0	CSN-X-4780A

X (Color code): 7:RAL 7035 Light Grey, 9:RAL 9005 Black

# Inorax-ST Network Cabinet

## Components of Inorax-ST Rack Cabinets

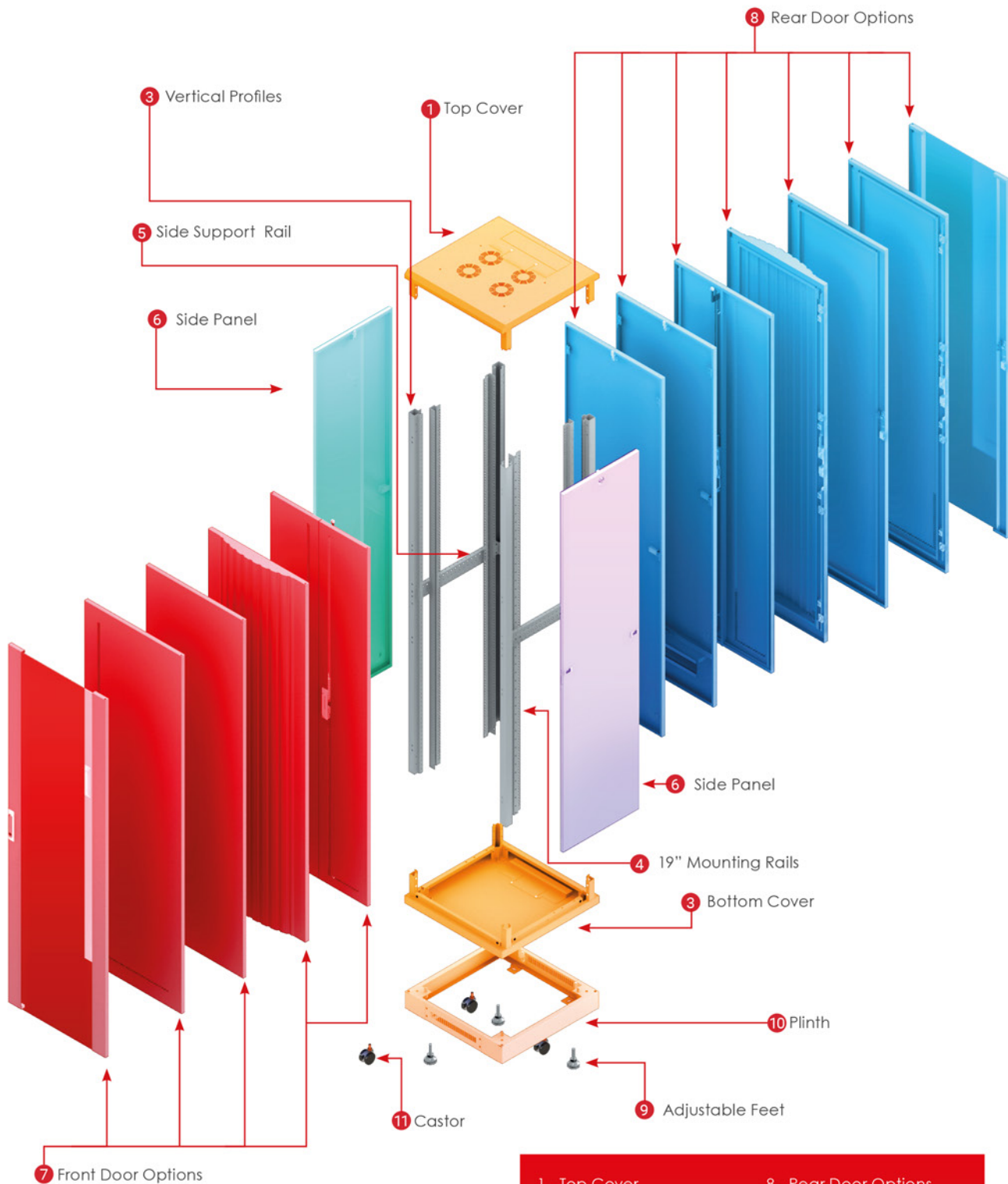

- |                        |                       |
|------------------------|-----------------------|
| 1 - Top Cover          | 8 - Rear Door Options |
| 2 - Bottom Cover       | 9 - Adjustable Feet   |
| 3 - Vertical Profiles  | 10 - Plinth           |
| 4 - 19" Mounting Rails | 11 - Castor           |
| 5 - Side Support Rails |                       |
| 6 - Side Panel         |                       |
| 7 - Front Door Options |                       |

## Inorax-ST Network Cabinet



Page : 123-124



Page : 124-126

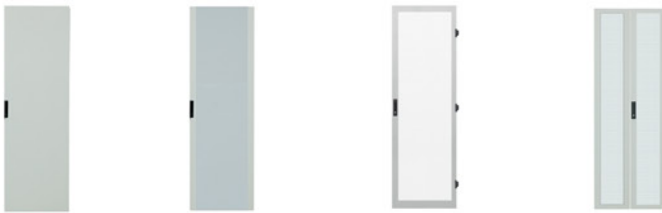

Page : 127-129



Page : 129-130

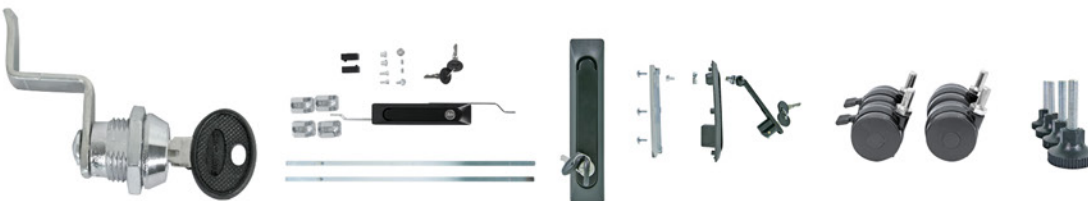

Page : 130-132

# Inorax-ST Network Cabinet

## Components of Inorax-ST Rack Cabinets

### Top Cover

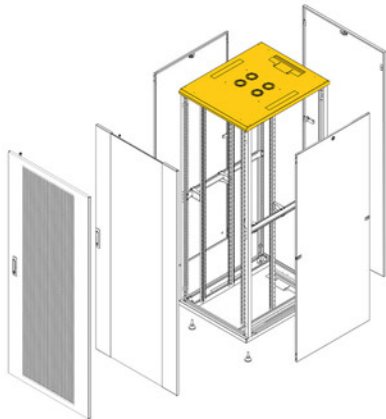
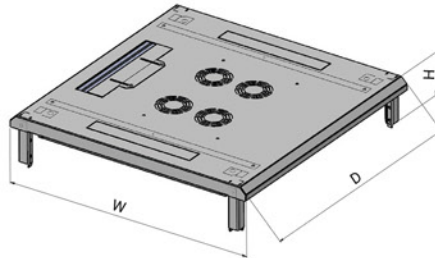

Component Position

### Top Cover Options

Material	1.5 mm Steel	Finish	Electrostatic Powder Paint	
Color	RAL 7035 (Light Grey) and RAL 9005 (Black)			
W (mm)	D (mm)	H (mm)	Weight kg	Part No
600	600	154	10,8	CSZ-X-YY660-0401
600	800	154	12,7	CSZ-X-YY680-0401
600	1000	154	14,6	CSZ-X-YY600-0401
600	1100	154	15,5	CSZ-X-YY610-0401
600	1200	154	16,4	CSZ-X-YY620-0401
800	800	154	16,7	CSZ-X-YY880-0401
800	1000	154	19,6	CSZ-X-YY800-0401
800	1100	154	21,0	CSZ-X-YY810-0401
800	1200	154	22,4	CSZ-X-YY820-0401

### Bottom Cover

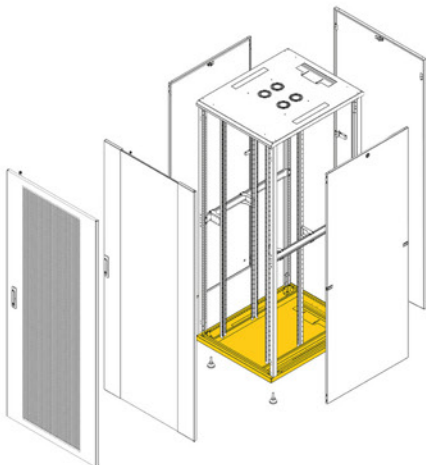
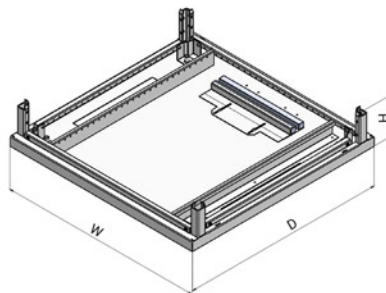
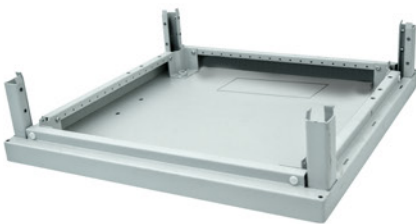

Component Position

### Bottom Cover Options

Material	1.5 mm Steel	Finish	Electrostatic Powder Paint	
Color	RAL 7035 (Light Grey) and RAL 9005 (Black)			
W (mm)	D (mm)	H (mm)	Weight kg	Part No
600	600	154	11,1	CSZ-X-YY660-0403
600	800	154	13,0	CSZ-X-YY680-0403
600	1000	154	15,0	CSZ-X-YY600-0403
600	1100	154	15,9	CSZ-X-YY610-0403
600	1200	154	16,9	CSZ-X-YY620-0403
800	800	154	17,2	CSZ-X-YY880-0403
800	1000	154	20,0	CSZ-X-YY800-0403
800	1100	154	21,5	CSZ-X-YY810-0403
800	1200	154	22,9	CSZ-X-YY820-0403

X (Color code): 7:RAL 7035 Light Grey, 9:RAL 9005 Black

# Inorax-ST Network Cabinet

## Vertical Profiles

### Vertical Profile Options

Material	1.5 mm Steel	Finish	Electrostatic Powder Paint		
Color	RAL 7035 (Light Grey) and RAL 9005 (Black)				
H (U)	W (mm)	D (mm)	H (mm)	Weight kg	Part No
16U	48,5	57	754	1,4	CSZ-X-16YY0-0300
22U	48,5	57	1021	1,8	CSZ-X-22YY0-0300
26U	48,5	57	1199	2,2	CSZ-X-26YY0-0300
32U	48,5	57	1465	2,6	CSZ-X-32YY0-0300
36U	48,5	57	1643	2,9	CSZ-X-36YY0-0300
39U	48,5	57	1777	3,2	CSZ-X-39YY0-0300
42U	48,5	57	1910	3,5	CSZ-X-42YY0-0300
47U	48,5	57	2132	3,8	CSZ-X-47YY0-0300

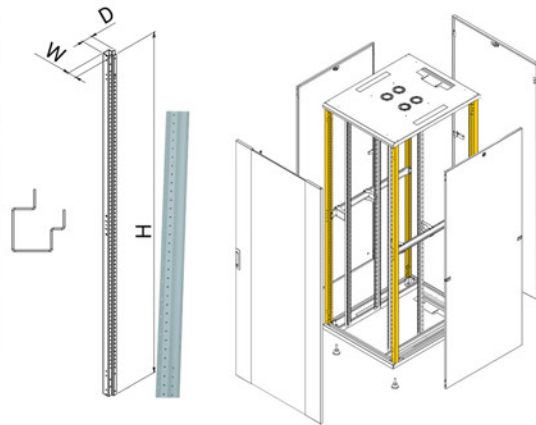

Component Position

### 19" Mounting Rail Options

Material	2 mm Steel	Finish	Zinc-Plated		
H (U)	W (mm)	D (mm)	H (mm)	Weight kg	Part No
16U	33	52	753	1,0	CSZ-0-16YY0-0600
22U	33	52	1020	1,3	CSZ-0-22YY0-0600
26U	33	52	1198	1,5	CSZ-0-26YY0-0600
32U	33	52	1464	1,8	CSZ-0-32YY0-0600
36U	33	52	1642	2,0	CSZ-0-36YY0-0600
39U	33	52	1776	2,2	CSZ-0-39YY0-0600
42U	33	52	1909	2,4	CSZ-0-42YY0-0600
47U	33	52	2131	2,7	CSZ-0-47YY0-0600

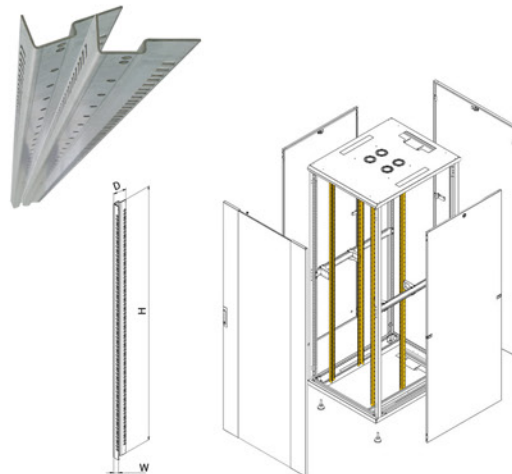

Component Position

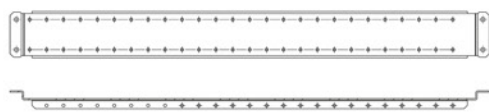

## Side Support Rails

### Side Support Rail Options

Material	2 mm Steel	Finish	Zinc-Plated
Cabinet W (mm)	Cabinet D (mm)	Weight kg	Part No
600	600	0,7	CSZ-0-YY660-0700
600	800	0,8	CSZ-0-YY680-0700
600	1000	0,8	CSZ-0-YY600-0700
600	1100	0,9	CSZ-0-YY610-0700
600	1200	0,9	CSZ-0-YY620-0700
800	800	0,8	CSZ-0-YY880-0700
800	1000	0,9	CSZ-0-YY800-0700
800	1100	1,0	CSZ-0-YY810-0700
800	1200	1,0	CSZ-0-YY820-0700

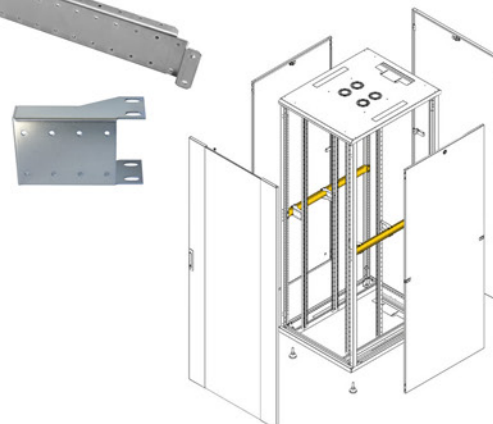

Component Position

X (Color code): 7:RAL 7035 Light Grey, 9:RAL 9005 Black

# Inorax-ST Network Cabinet

## Side Panel

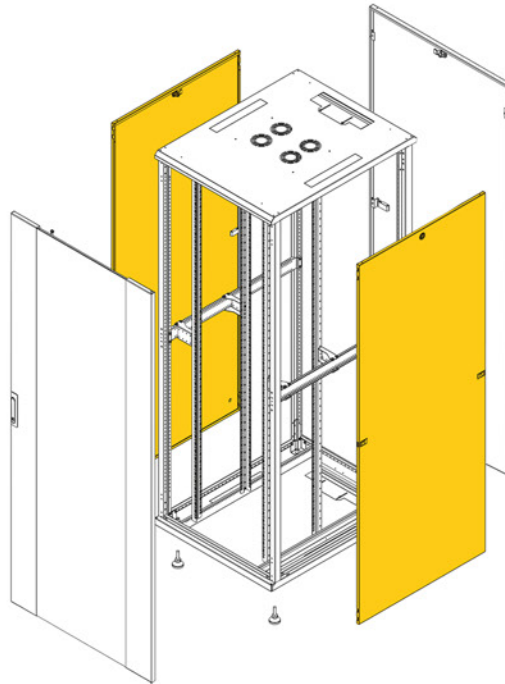
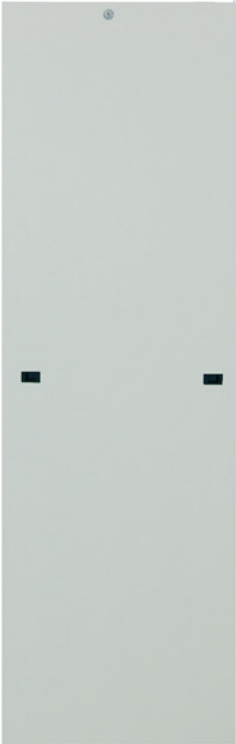

Component Position

## Side Panel Options

Material	1 mm Steel	Finish	Electrostatic Powder Paint
Color	RAL 7035 (Light Grey) and RAL 9005 (Black)		

H (U)	W (mm)	D (mm)	H (mm)	Part No
16U	600	22	749	CSZ-X-16Y60-0501
22U	600	22	1016	CSZ-X-22Y60-0501
22U	800	22	1016	CSZ-X-22Y80-0501
26U	600	22	1194	CSZ-X-26Y60-0501
26U	800	22	1194	CSZ-X-26Y80-0501
26U	1000	22	1194	CSZ-X-26Y00-0501
32U	600	22	1460	CSZ-X-32Y60-0501
32U	800	22	1460	CSZ-X-32Y80-0501
36U	600	22	1638	CSZ-X-36Y60-0501
36U	800	22	1638	CSZ-X-36Y80-0501
36U	1000	22	1638	CSZ-X-36Y00-0501
36U	1200	22	1638	CSZ-X-36Y20-0501
39U	800	22	1772	CSZ-X-39Y80-0501
39U	1000	22	1772	CSZ-X-39Y00-0501
42U	600	22	1905	CSZ-X-42Y60-0501
42U	800	22	1905	CSZ-X-42Y80-0501
42U	1000	22	1905	CSZ-X-42Y00-0501
42U	1100	22	1905	CSZ-X-42Y10-0501
42U	1200	22	1905	CSZ-X-42Y20-0501
47U	600	22	2127	CSZ-X-47Y60-0501
47U	800	22	2127	CSZ-X-47Y80-0501
47U	1000	22	2127	CSZ-X-47Y00-0501
47U	1100	22	2127	CSZ-X-47Y10-0501
47U	1200	22	2127	CSZ-X-47Y20-0501

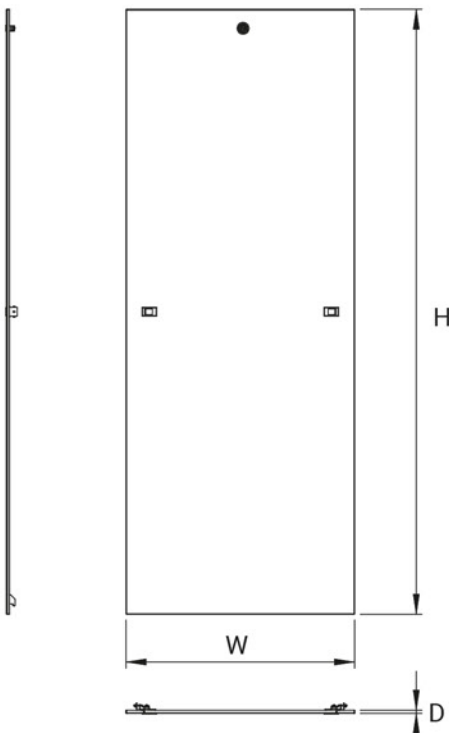

X (Color code): 7:RAL 7035 Light Grey, 9:RAL 9005 Black

# Inorax-ST Network Cabinet

## Rear Metal Solid Panel

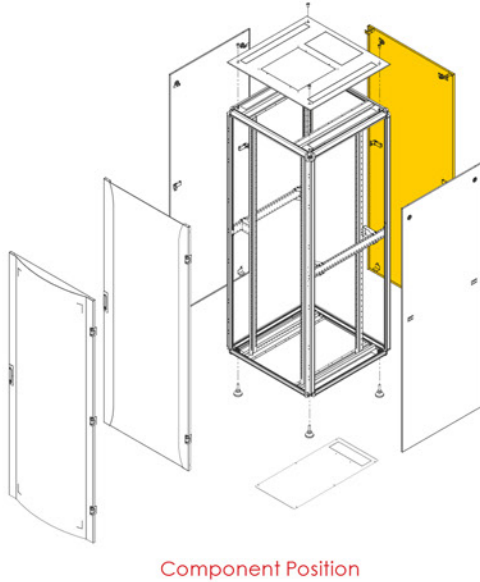

## Rear Metal Solid Panel Options

Material	1 mm Steel		Finish	Zinc-Plated		
H (U)	W (mm)	D (mm)	H (mm)	Weight kg	Part No	
16U	600	23	752	5.1	CSZ-X-166Y0-0901	
22U	600	23	1018	6,7	CSZ-X-226Y0-0901	
22U	800	23	1018	8,8	CSZ-X-228Y0-0901	
26U	600	23	1196	7,8	CSZ-X-266Y0-0901	
26U	800	23	1196	10,2	CSZ-X-268Y0-0901	
32U	600	23	1463	9,5	CSZ-X-326Y0-0901	
32U	800	23	1463	12,3	CSZ-X-328Y0-0901	
36U	600	23	1641	10,6	CSZ-X-366Y0-0901	
36U	800	23	1641	13,8	CSZ-X-368Y0-0901	
39U	800	23	1774	14,9	CSZ-X-398Y0-0901	
42U	600	23	1907	12,2	CSZ-X-426Y0-0901	
42U	800	23	1907	16,0	CSZ-X-428Y0-0901	
47U	600	23	2130	13,6	CSZ-X-476Y0-0901	
47U	800	23	2130	17,7	CSZ-X-478Y0-0901	

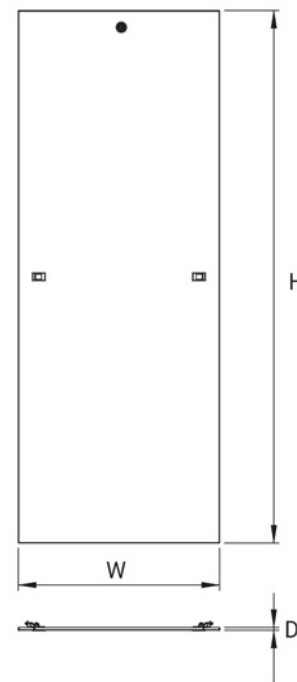

X (Color code): 7:RAL 7035 Light Grey, 9:RAL 9005 Black



# Inorax-ST Network Cabinet

## Single Door Options Metal Solid Door

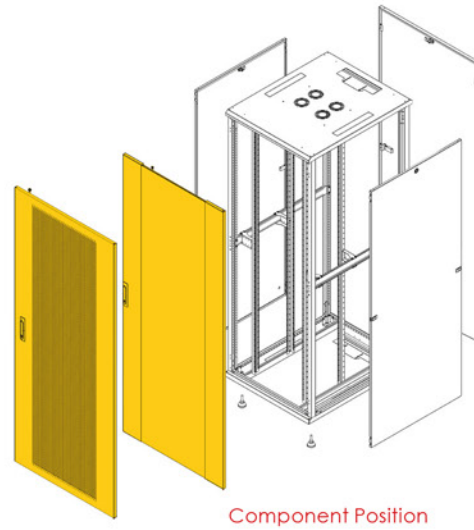
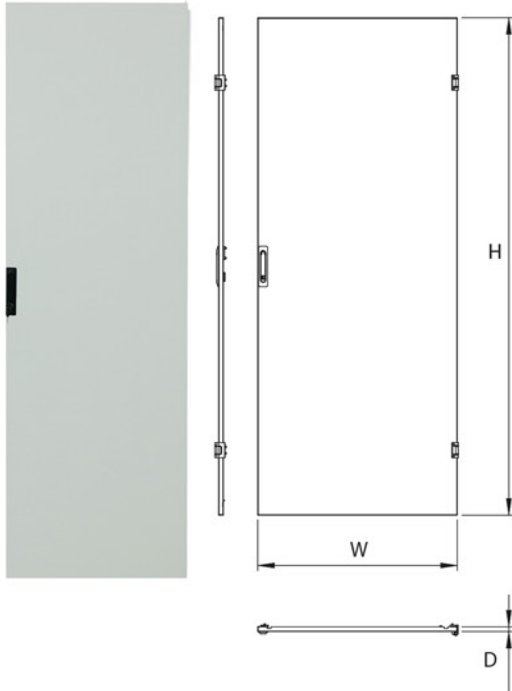

## Metal Solid Door Options

Material	1.2 mm Steel	Finish	Electrostatic Powder Paint
Color	RAL 7035 (Light Grey) and RAL 9005 (Black)		

H (U)	W (mm)	D (mm)	H (mm)	Weight kg	Part No
16U	600	22	749	6,87	CSZ-X-166Y0-0902
22U	600	22	1016	8,94	CSZ-X-226Y0-0902
22U	800	22	1016	11,26	CSZ-X-228Y0-0902
26U	600	22	1194	10,32	CSZ-X-266Y0-0902
26U	800	22	1194	12,97	CSZ-X-268Y0-0902
32U	600	22	1460	12,39	CSZ-X-326Y0-0902
32U	800	22	1460	15,54	CSZ-X-328Y0-0902
36U	600	22	1638	13,77	CSZ-X-366Y0-0902
36U	800	22	1638	17,26	CSZ-X-368Y0-0902
39U	800	22	1772	18,54	CSZ-X-398Y0-0902
42U	600	22	1905	15,84	CSZ-X-426Y0-0902
42U	800	22	1905	19,83	CSZ-X-428Y0-0902
47U	600	22	2127	17,56	CSZ-X-476Y0-0902
47U	800	22	2127	21,97	CSZ-X-478Y0-0902

## Glass Door

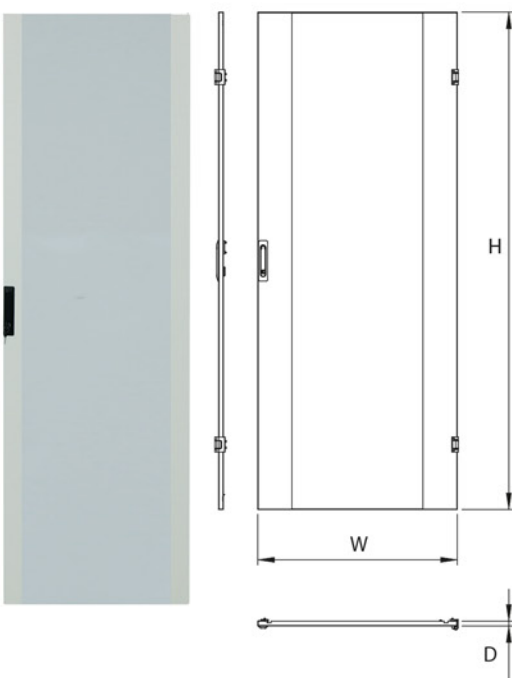

## Glass Door Options

Material	1.2 mm Steel	Finish	Electrostatic Powder Paint
Color	RAL 7035 (Light Grey) and RAL 9005 (Black)		

H (U)	W (mm)	D (mm)	H (mm)	Weight kg	Part No
16U	600	22	749	5,53	CSZ-X-166Y0-0903
22U	600	22	1016	7,42	CSZ-X-226Y0-0903
22U	800	22	1016	9,77	CSZ-X-228Y0-0903
26U	600	22	1194	8,68	CSZ-X-266Y0-0903
26U	800	22	1194	11,42	CSZ-X-268Y0-0903
32U	600	22	1460	10,56	CSZ-X-326Y0-0903
32U	800	22	1460	13,9	CSZ-X-328Y0-0903
36U	600	22	1638	11,82	CSZ-X-366Y0-0903
36U	800	22	1638	15,55	CSZ-X-368Y0-0903
39U	800	22	1772	16,79	CSZ-X-398Y0-0903
42U	600	22	1905	13,7	CSZ-X-426Y0-0903
42U	800	22	1905	18,02	CSZ-X-428Y0-0903
47U	600	22	2127	15,27	CSZ-X-476Y0-0903
47U	800	22	2127	20,09	CSZ-X-478Y0-0903

X (Color code): 7:RAL 7035 Light Grey, 9:RAL 9005 Black

# Inorax-ST Network Cabinet

## Perforated Flat Door

### Perforated Flat Door Options

<b>Material</b>	1.2 mm Steel	<b>Color</b>	RAL 7035 (Light Grey) and RAL 9005 (Black)
<b>Finish</b>	Electrostatic Powder Paint	<b>Perforation Rate</b>	65%

H (U)	W (mm)	D (mm)	H (mm)	Weight kg	Part No
26U	600	22	1194	7,81	CSZ-X-266Y0-0904
36U	600	22	1638	10,15	CSZ-X-366Y0-0904
39U	800	22	1772	14,02	CSZ-X-398Y0-0904
42U	600	22	1905	11,80	CSZ-X-426Y0-0904
42U	800	22	1905	15,17	CSZ-X-428Y0-0904
47U	600	22	2127	12,97	CSZ-X-476Y0-0904
47U	800	22	2127	16,69	CSZ-X-478Y0-0904

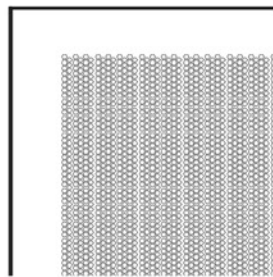

Perforation Detail

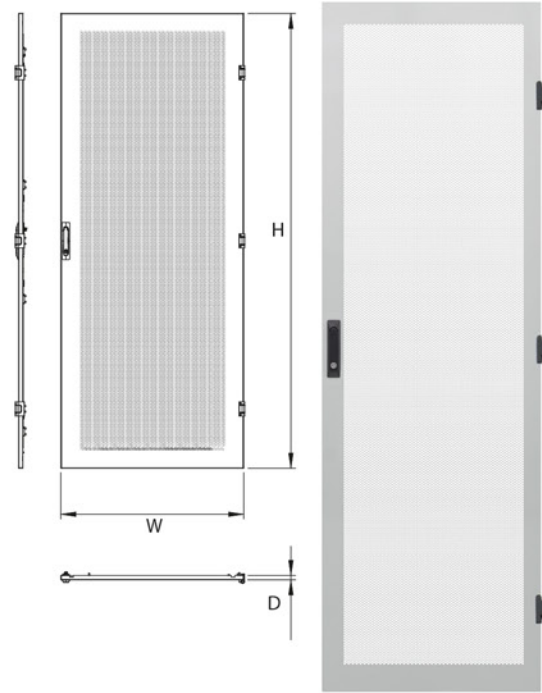

### High Perforation Rated Flat Door Options

<b>Material</b>	1.2 mm Steel	<b>Color</b>	RAL 7035 (Light Grey) and RAL 9005 (Black)
<b>Finish</b>	Electrostatic Powder Paint	<b>Perforation Rate</b>	80%

H (U)	W (mm)	D (mm)	H (mm)	Weight kg	Part No
26U	600	22	1194	7,51	CSZ-X-266Y0-0909
36U	600	22	1638	9,85	CSZ-X-366Y0-0909
39U	800	22	1772	13,72	CSZ-X-398Y0-0909
42U	600	22	1905	11,50	CSZ-X-426Y0-0909
42U	800	22	1905	14,87	CSZ-X-428Y0-0909
47U	600	22	2127	12,67	CSZ-X-476Y0-0909
47U	800	22	2127	16,39	CSZ-X-478Y0-0909

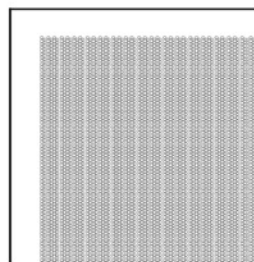

Perforation Detail

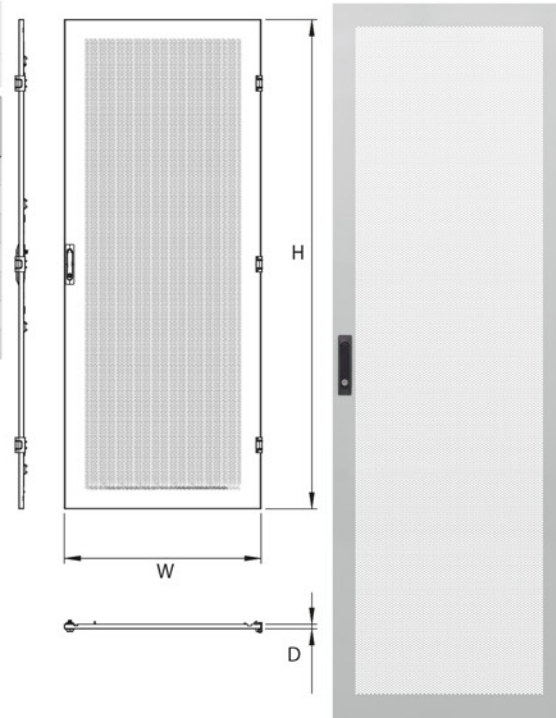

X (Color code): 7:RAL 7035 Light Grey, 9:RAL 9005 Black

# Inorax-ST Network Cabinet

## Double Door Options Double Perforated Door

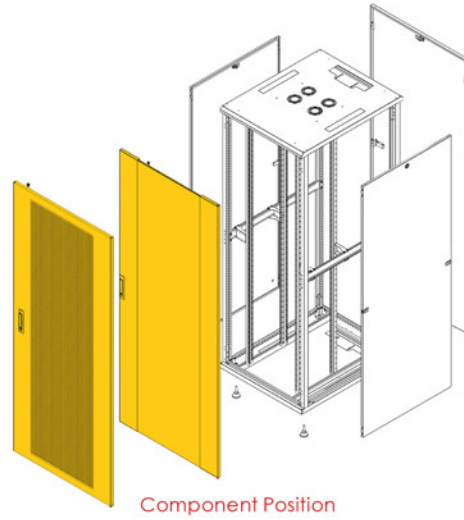
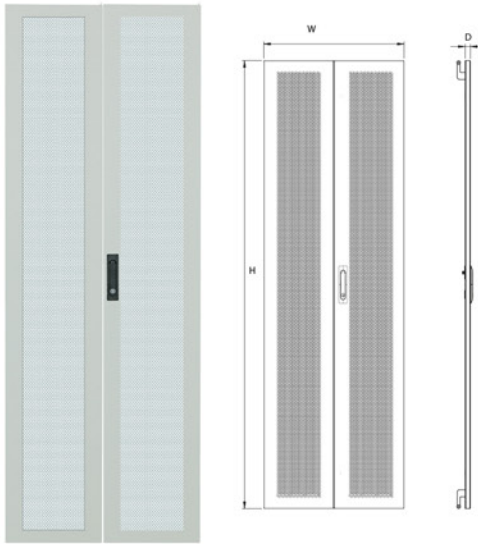

## Double Perforated Door Options

<b>Material</b>	1.2 mm Steel	<b>Color</b>	RAL 7035 (Light Grey) and RAL 9005 (Black)		
<b>Finish</b>	Electrostatic Powder Paint		<b>Perforation Rate</b>	65%	
<b>H (U)</b>	<b>W (mm)</b>	<b>D (mm)</b>	<b>H (mm)</b>	<b>Weight kg</b>	<b>Part No</b>
26U	600	22	1194	11,99	CSZ-X-266Y0-0908
36U	600	22	1638	15,70	CSZ-X-366Y0-0908
39U	800	22	1772	21,19	CSZ-X-398Y0-0908
42U	600	22	1905	18,16	CSZ-X-426Y0-0908
42U	800	22	1905	22,83	CSZ-X-428Y0-0908
47U	600	22	2127	20,01	CSZ-X-476Y0-0908
47U	800	22	2127	25,16	CSZ-X-478Y0-0908

## High Perforation Rated Double Door

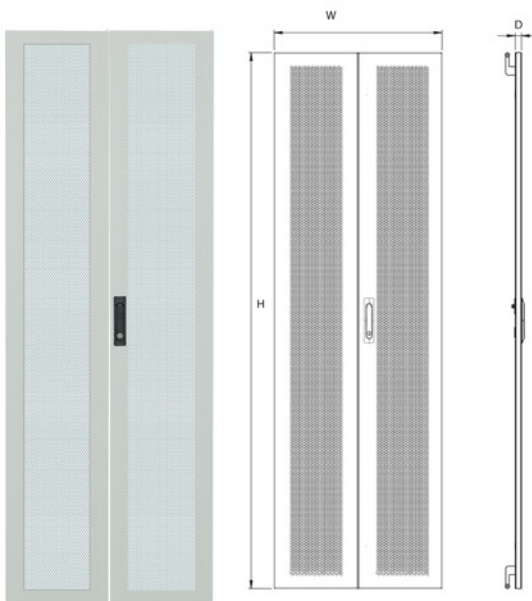

## High Perforation Rated Double Door Options

<b>Material</b>	1.2 mm Steel	<b>Color</b>	RAL 7035 (Light Grey) and RAL 9005 (Black)		
<b>Finish</b>	Electrostatic Powder Paint		<b>Perforation Rate</b>	80%	
<b>H (U)</b>	<b>W (mm)</b>	<b>D (mm)</b>	<b>H (mm)</b>	<b>Weight kg</b>	<b>Part No</b>
26U	600	22	1194	11,69	CSZ-X-266Y0-0911
36U	600	22	1638	15,40	CSZ-X-366Y0-0911
39U	800	22	1772	20,89	CSZ-X-398Y0-0911
42U	600	22	1905	17,86	CSZ-X-426Y0-0911
42U	800	22	1905	22,53	CSZ-X-428Y0-0911
47U	600	22	2127	19,71	CSZ-X-476Y0-0911
47U	800	22	2127	24,86	CSZ-X-478Y0-0911

X (Color code): 7:RAL 7035 Light Grey, 9:RAL 9005 Black

# Inorax-ST Network Cabinet

## Rear Metal Panel with Cable Entry

Material	1 mm Steel	Finish	Electrostatic Powder Paint		
Color	RAL 7035 (Light Grey) and RAL 9005 (Black)				
H (U)	W (mm)	D (mm)	H (mm)	Weight kg	Part No
3U	600	23	133	0,97	CSZ-X-036Y0-0915
3U	800	23	133	1,35	CSZ-X-038Y0-0915
4U	600	23	177	1,24	CSZ-X-046Y0-0915
4U	800	23	177	1,71	CSZ-X-048Y0-0915
5U	600	23	222	1,52	CSZ-X-056Y0-0915
5U	800	23	222	2,06	CSZ-X-058Y0-0915
6U	600	23	266	1,79	CSZ-X-066Y0-0915
6U	800	23	266	2,42	CSZ-X-068Y0-0915



Component Position



## Adjustable Cable Entry Panel with EPDM Gasket

Material	1 mm Steel	Finish	Electrostatic Powder Paint	
Color	RAL 7035 (Light Grey) and RAL 9005 (Black)			
W (mm)	D (mm)	H (mm)	Weight kg	Part No
350	152	20	0,53	CSZ-X-YYYY0-0803



## Adjustable Feet

Material	Steel and Plastic ABS	Finish	Zinc Plated
Packaging	4 pieces in a box		
Maximum Static Load	Set Weight kg	Part No	
600 kg / piece	0.35	CCA-0-7014	

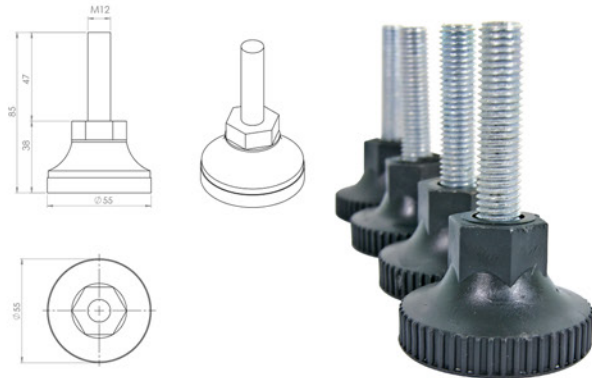

## Castor Set

Material	Steel and Plastic ABS	Finish	Zinc Plated
Packaging	2 pcs with stopper and 2 pcs without stopper in a box		
Maximum Static Load	Set Weight kg	Part No	
75 kg / piece	0.77	CCA-0-7015	

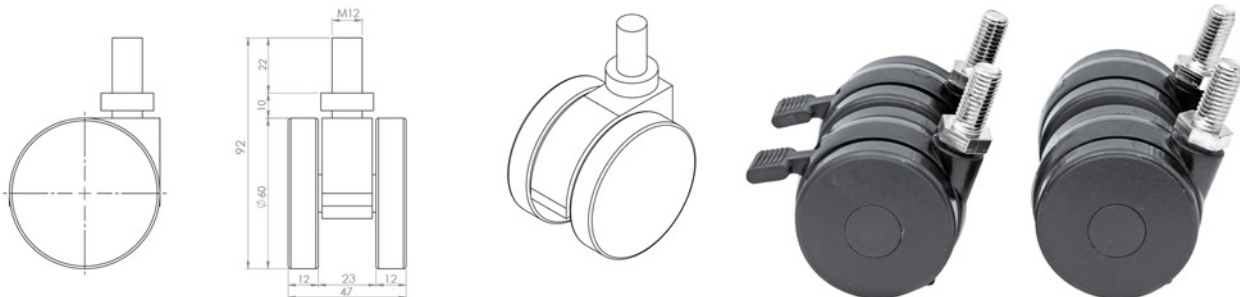

X (Color code): 7:RAL 7035 Light Grey, 9:RAL 9005 Black

## Inorax-ST Network Cabinet

### Locking Device Systems

#### Multi Point Lock for Double Doors

Material	Steel, Polyamide
Packaging	1 piece in a box
Part No	CSZ-0-YYYY0-1005

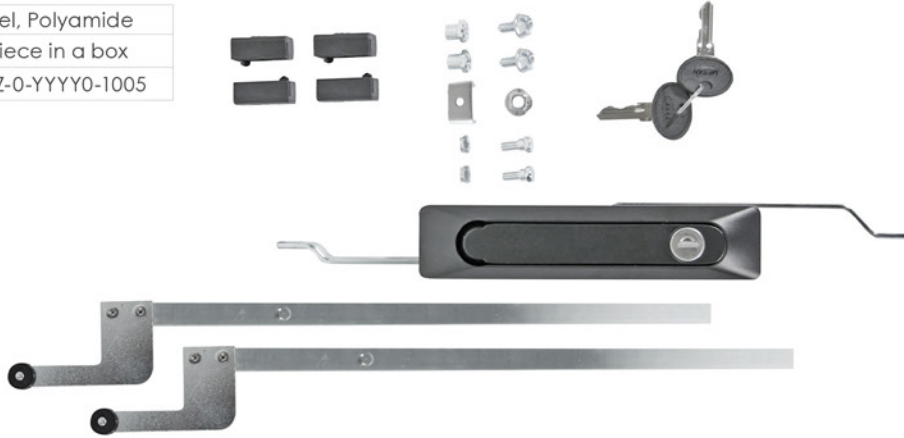

#### Four Point Lock for Single Curved Perforated Door

Material	Steel, Polyamide
Packaging	1 piece in a box
Part No	CSZ-0-YYYY0-1004



#### Three Point Lock for Single Perforated Door

Material	Steel, Polyamide
Packaging	1 piece in a box
Part No	CSZ-0-YYYY0-1006

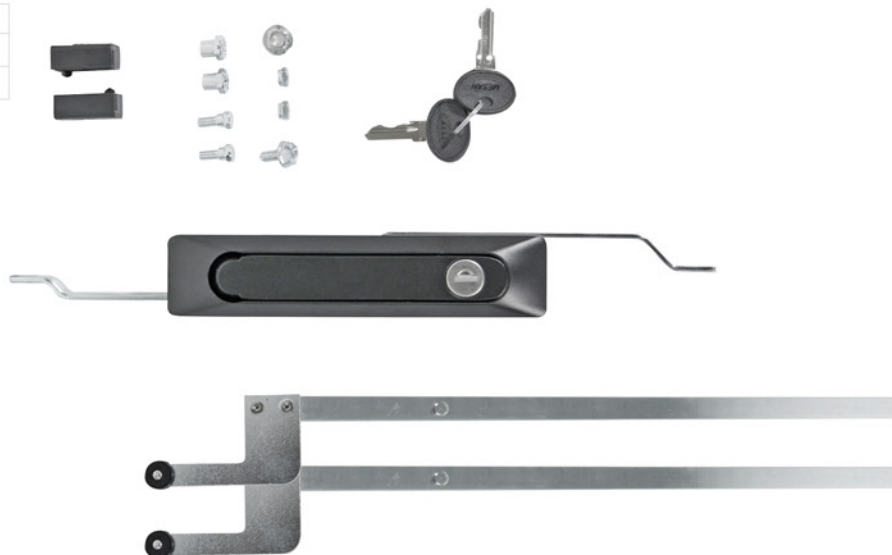

**Inorax-ST Network Cabinet**



**Single Point Lock**

Material	Polyamide
Packaging	1 piece in a box
Part No	CPZ-0-YYYY0-1003

**Cylindrical Lock for Side Panel**



Material	Zamak, Steel
Packaging	1 piece in a box
Part No	CPZ-0-YYYY0-1001

**Cylindrical Lock for Rear Metal Solid Panel**



Material	Zamak, Steel
Packaging	1 piece in a box
Part No	CPZ-0-YYYY0-1002

## Inorax-ST Server Cabinet



### Inorax-ST Server Cabinet

A cost effective server rack cabinet system developed for independent use and Data Center environments. Inorax-ST server rack cabinet system is designed and engineered for demanding Data Center environments. It is designed to house all servers manufactured by major brands including HP, Dell, Sun, Cisco, Juniper, IBM, Compaq to name but a few. To achieve optimum versatility within the server rack, users can set multiple depths throughout the cabinet by adjustable 19" mounting rails mounted on heavy duty side supports. Horizontally divided side panels provide ease of access and convenient post-installation maintenance. Optional 80% perforations on front and rear doors enable optimum airflow within the rack cabinet. Optional cable tray channels can be fitted on top of the rack provides perfect cable routing eliminating the need for raised floor systems. Flat-pack option enables savings up to 60% in the transport cost and warehouse space

### Technical Features

Material	1-1,2-1,5-2mm Steel
Color	RAL 7035 or RAL 9005
Compliance	RoHS, UL Certified
Packaging	Assembled or unassembled
Maximum Static Load	Up to 1500 kg.
Finish	Frame, doors, side panels, top and bottom covers. Electrostatic Powder Paint, 19" mounting rails: Zinc-plated

### Standard Configuration

- Perforated front and rear doors, Free Air Ratio (FAR): %65
- Front & rear doors with swing handle Multi point-espagnolette
- Solid Side Panels with cylindrical locks and latches
- Internal top sheet with 3 cable entries for 800 width, 1 cable entry for 600 width racks and fan cut-outs
- 2 Pairs of depth adjustable heavy duty 19" Mounting Rails
- 2 Pairs of Adjustable Feet
- Bottom cover with 3 cable entries for 800 width, 1 cable entry for 600 width racks



**CERTIFIED**



Front View



Front View Open



3/4 View



Side View

# Inorax-ST Server Cabinet

## Technical Drawing

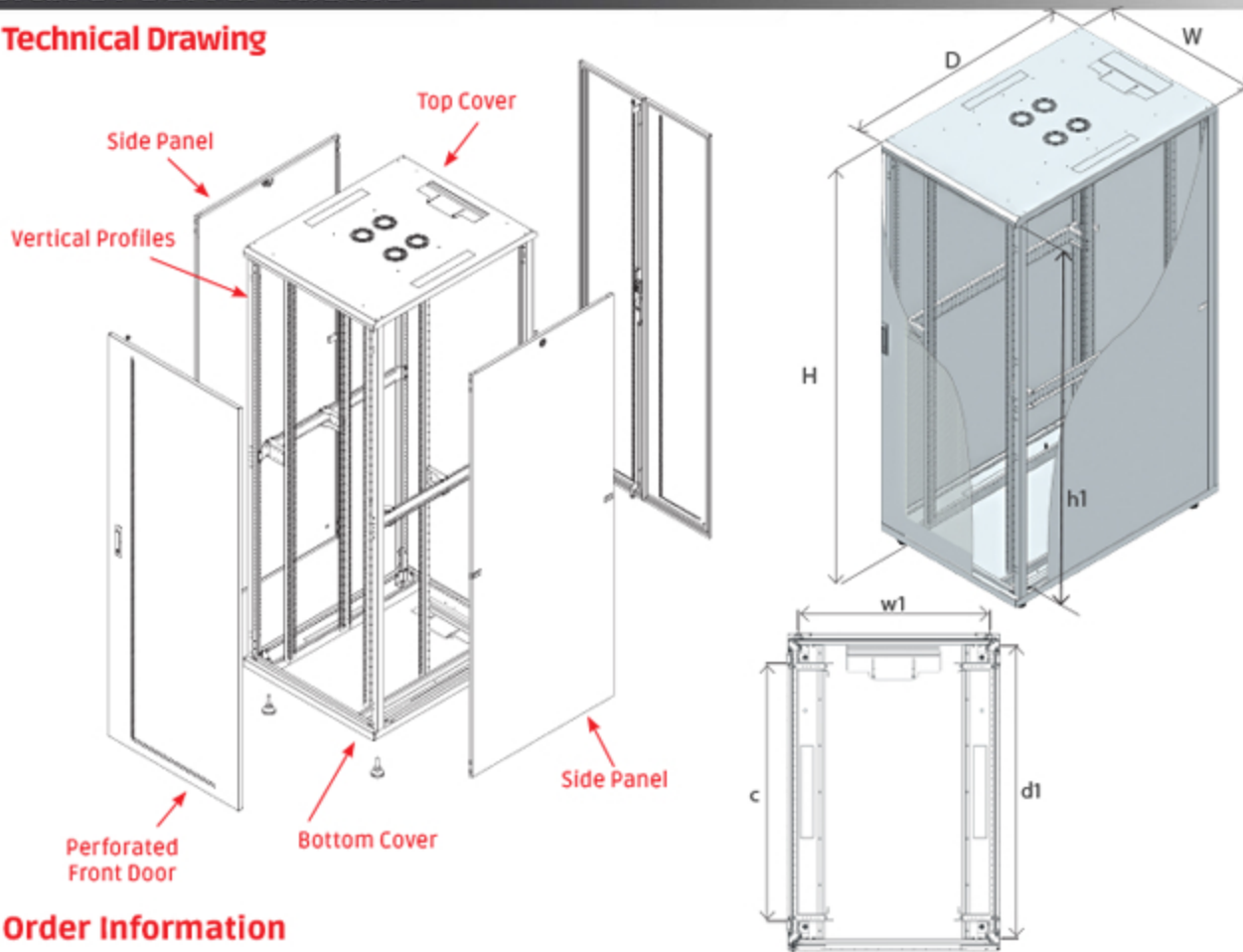

## Order Information

Height U	Outer Width (w) mm	Outer Depth (D) mm	Outer Height (H) mm	Inner Width (w1) mm	Inner Depth (d1) mm	Inner Height (h1) mm	19" Rails Adjustable Depth Range (c)	Weight kg	Part No
26U	600	1000	1322	503	950	1162	123 - 773	84,0	CSS-X-2660A
26U	600	1200	1322	503	1150	1162	123 - 973	95,8	CSS-X-2662A
36U	600	1000	1766	503	950	1607	123 - 773	104,9	CSS-X-3660A
36U	600	1200	1766	503	1150	1607	123 - 973	116,5	CSS-X-3662A
39U	800	1000	1900	703	950	1740	123 - 773	130,2	CSS-X-3980A
42U	600	1000	2033	503	950	1873	123 - 773	117,2	CSS-X-4260A
42U	600	1100	2033	503	1050	1873	123 - 873	123,0	CSS-X-4261A
42U	600	1200	2033	503	1150	1873	123 - 973	129,0	CSS-X-4262A
42U	800	1000	2033	703	950	1873	123 - 773	136,9	CSS-X-4280A
42U	800	1100	2033	703	1050	1873	123 - 873	143,6	CSS-X-4281A
42U	800	1200	2033	703	1150	1873	123 - 973	150,5	CSS-X-4282A
42U	1000	1000	2033	903	950	1873	123 - 773	156,9	CSS-X-4211A
44U	600	1000	2122	903	950	1962	123 - 773	156,9	CSS-X-4461A
47U	600	1000	2255	503	950	2095	123 - 773	126,7	CSS-X-4760A
47U	600	1100	2255	503	1050	2095	123 - 873	133,0	CSS-X-4761A
47U	600	1200	2255	503	1150	2095	123 - 973	139,3	CSS-X-4762A
47U	800	1000	2255	703	950	2095	123 - 773	147,3	CSS-X-4780A
47U	800	1100	2255	703	1050	2095	123 - 873	154,5	CSS-X-4781A
47U	800	1200	2255	703	1150	2095	123 - 973	161,7	CSS-X-4782A

X (Color code): 7:RAL 7035 Light Grey, 9:RAL 9005 Black



# Inorax-ST Network Cabinet

## Components of Inorax-ST Rack Cabinets

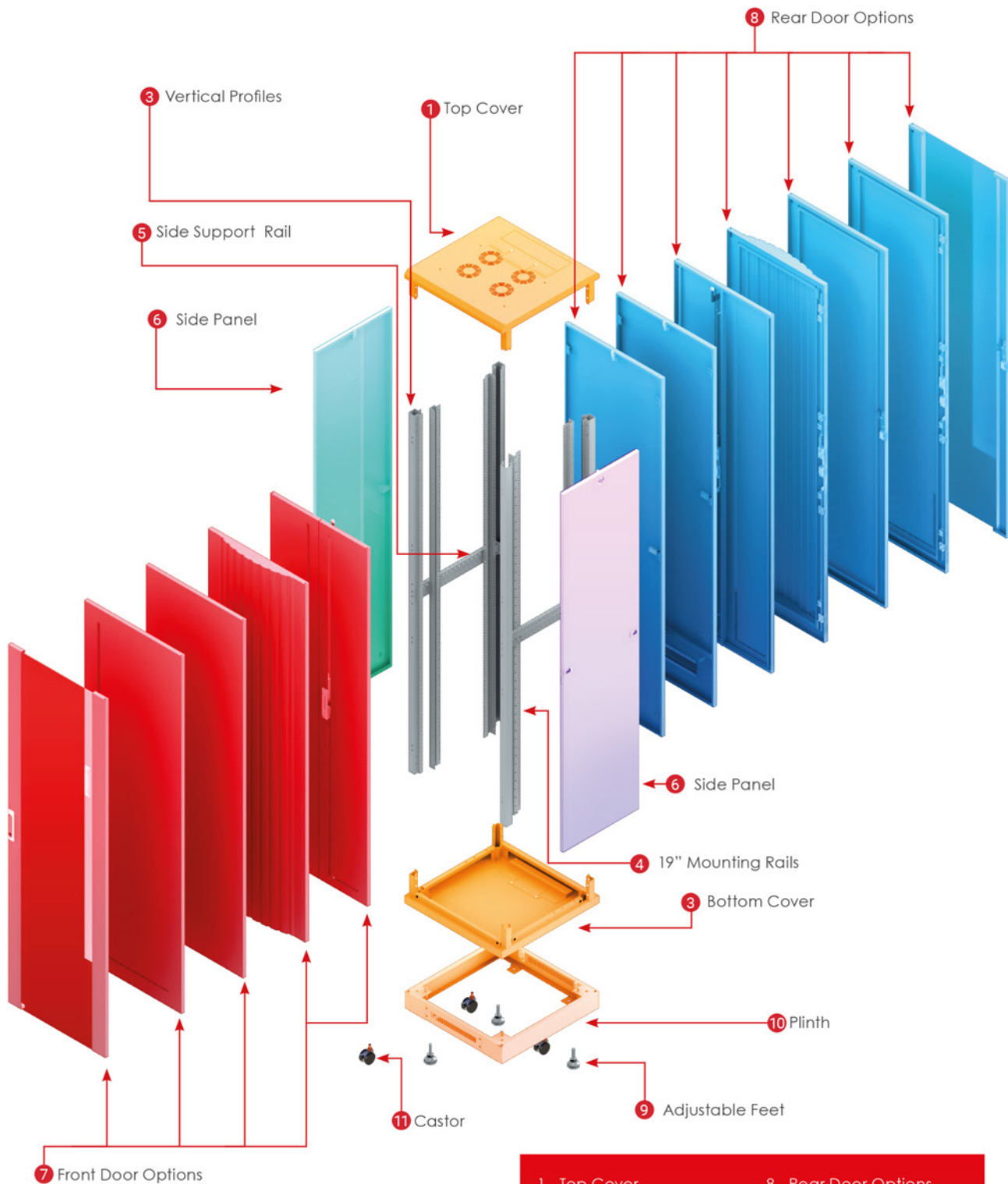

- |                        |                       |
|------------------------|-----------------------|
| 1 - Top Cover          | 8 - Rear Door Options |
| 2 - Bottom Cover       | 9 - Adjustable Feet   |
| 3 - Vertical Profiles  | 10 - Plinth           |
| 4 - 19" Mounting Rails | 11 - Castor           |
| 5 - Side Support Rails |                       |
| 6 - Side Panel         |                       |
| 7 - Front Door Options |                       |

## Inorax-ST Network Cabinet



Page : 123-124



Page : 124-126

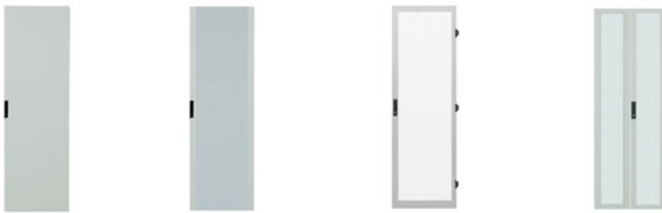

Page : 127-129



Page : 129-130

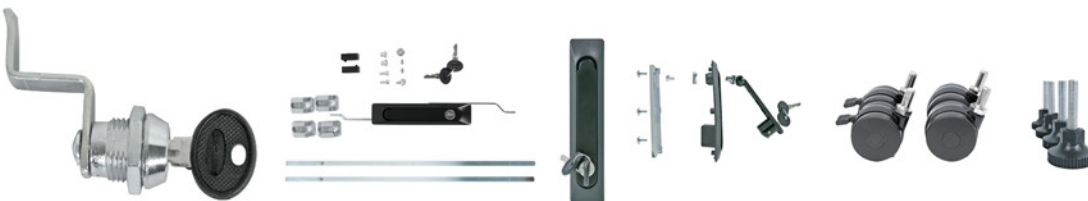

Page : 130-132

# Inorax-ST Network Cabinet

## Components of Inorax-ST Rack Cabinets

### Top Cover

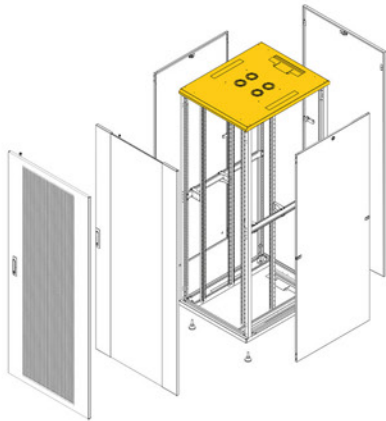
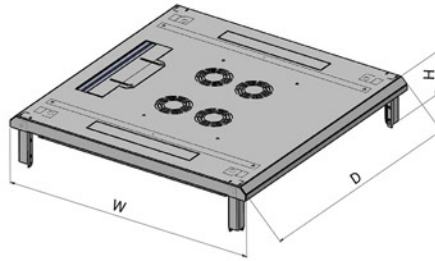

Component Position

### Top Cover Options

Material	1.5 mm Steel	Finish	Electrostatic Powder Paint	
Color	RAL 7035 (Light Grey) and RAL 9005 (Black)			
W (mm)	D (mm)	H (mm)	Weight kg	Part No
600	600	154	10,8	CSZ-X-YY660-0401
600	800	154	12,7	CSZ-X-YY680-0401
600	1000	154	14,6	CSZ-X-YY600-0401
600	1100	154	15,5	CSZ-X-YY610-0401
600	1200	154	16,4	CSZ-X-YY620-0401
800	800	154	16,7	CSZ-X-YY880-0401
800	1000	154	19,6	CSZ-X-YY800-0401
800	1100	154	21,0	CSZ-X-YY810-0401
800	1200	154	22,4	CSZ-X-YY820-0401

### Bottom Cover

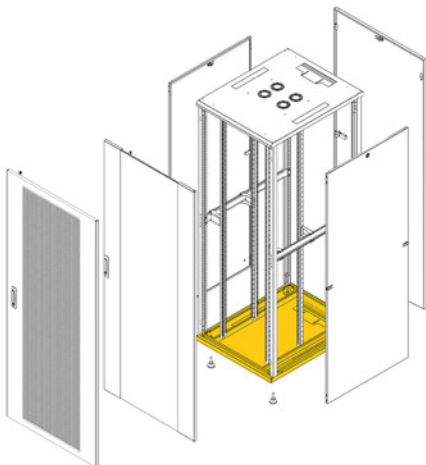
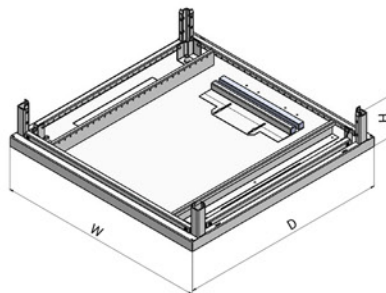
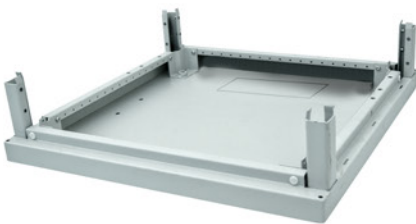

Component Position

### Bottom Cover Options

Material	1.5 mm Steel	Finish	Electrostatic Powder Paint	
Color	RAL 7035 (Light Grey) and RAL 9005 (Black)			
W (mm)	D (mm)	H (mm)	Weight kg	Part No
600	600	154	11,1	CSZ-X-YY660-0403
600	800	154	13,0	CSZ-X-YY680-0403
600	1000	154	15,0	CSZ-X-YY600-0403
600	1100	154	15,9	CSZ-X-YY610-0403
600	1200	154	16,9	CSZ-X-YY620-0403
800	800	154	17,2	CSZ-X-YY880-0403
800	1000	154	20,0	CSZ-X-YY800-0403
800	1100	154	21,5	CSZ-X-YY810-0403
800	1200	154	22,9	CSZ-X-YY820-0403

X (Color code): 7:RAL 7035 Light Grey, 9:RAL 9005 Black

# Inorax-ST Network Cabinet

## Vertical Profiles

### Vertical Profile Options

Material	1.5 mm Steel	Finish	Electrostatic Powder Paint		
Color	RAL 7035 (Light Grey) and RAL 9005 (Black)				
H (U)	W (mm)	D (mm)	H (mm)	Weight kg	Part No
16U	48,5	57	754	1,4	CSZ-X-16YY0-0300
22U	48,5	57	1021	1,8	CSZ-X-22YY0-0300
26U	48,5	57	1199	2,2	CSZ-X-26YY0-0300
32U	48,5	57	1465	2,6	CSZ-X-32YY0-0300
36U	48,5	57	1643	2,9	CSZ-X-36YY0-0300
39U	48,5	57	1777	3,2	CSZ-X-39YY0-0300
42U	48,5	57	1910	3,5	CSZ-X-42YY0-0300
47U	48,5	57	2132	3,8	CSZ-X-47YY0-0300

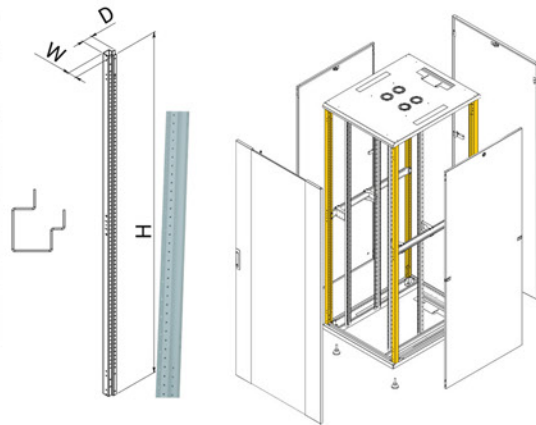

Component Position

### 19" Mounting Rail Options

Material	2 mm Steel	Finish	Zinc-Plated		
H (U)	W (mm)	D (mm)	H (mm)	Weight kg	Part No
16U	33	52	753	1,0	CSZ-0-16YY0-0600
22U	33	52	1020	1,3	CSZ-0-22YY0-0600
26U	33	52	1198	1,5	CSZ-0-26YY0-0600
32U	33	52	1464	1,8	CSZ-0-32YY0-0600
36U	33	52	1642	2,0	CSZ-0-36YY0-0600
39U	33	52	1776	2,2	CSZ-0-39YY0-0600
42U	33	52	1909	2,4	CSZ-0-42YY0-0600
47U	33	52	2131	2,7	CSZ-0-47YY0-0600

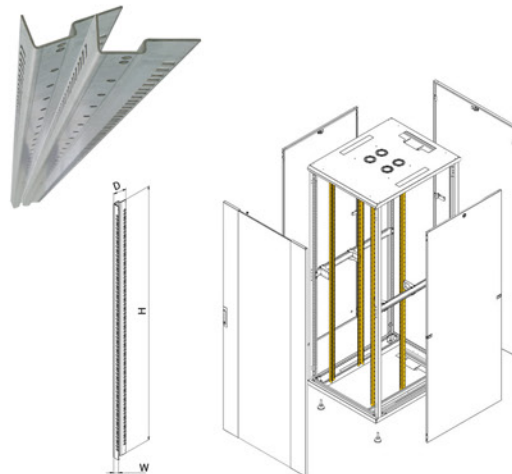

Component Position

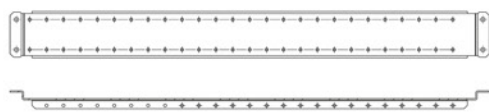

## Side Support Rails

### Side Support Rail Options

Material	2 mm Steel	Finish	Zinc-Plated
Cabinet W (mm)	Cabinet D (mm)	Weight kg	Part No
600	600	0,7	CSZ-0-YY660-0700
600	800	0,8	CSZ-0-YY680-0700
600	1000	0,8	CSZ-0-YY600-0700
600	1100	0,9	CSZ-0-YY610-0700
600	1200	0,9	CSZ-0-YY620-0700
800	800	0,8	CSZ-0-YY880-0700
800	1000	0,9	CSZ-0-YY800-0700
800	1100	1,0	CSZ-0-YY810-0700
800	1200	1,0	CSZ-0-YY820-0700

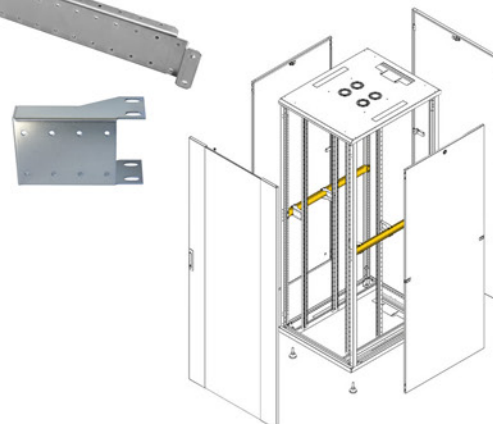

Component Position

X (Color code): 7:RAL 7035 Light Grey, 9:RAL 9005 Black

# Inorax-ST Network Cabinet

## Side Panel

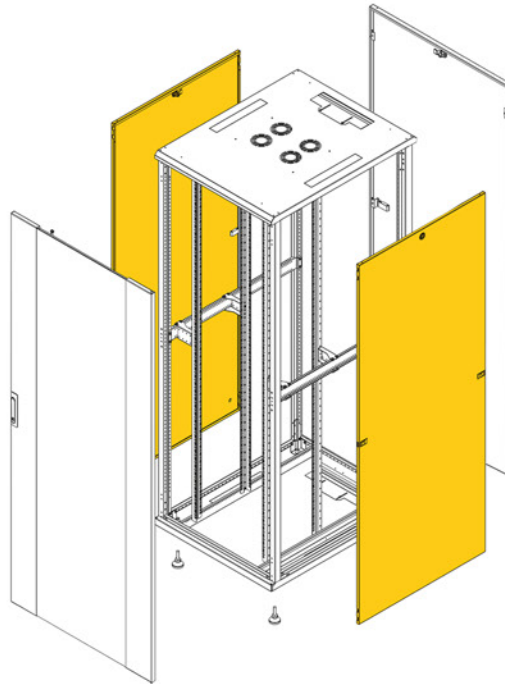
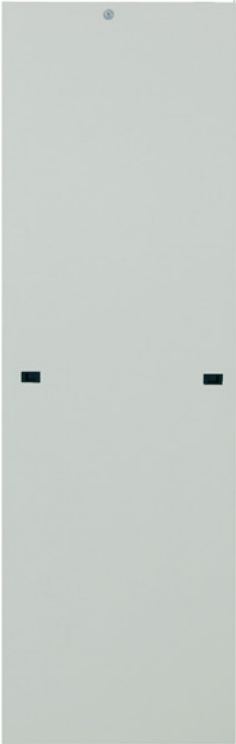

Component Position

## Side Panel Options

Material	1 mm Steel	Finish	Electrostatic Powder Paint
Color	RAL 7035 (Light Grey) and RAL 9005 (Black)		

H (U)	W (mm)	D (mm)	H (mm)	Part No
16U	600	22	749	CSZ-X-16Y60-0501
22U	600	22	1016	CSZ-X-22Y60-0501
22U	800	22	1016	CSZ-X-22Y80-0501
26U	600	22	1194	CSZ-X-26Y60-0501
26U	800	22	1194	CSZ-X-26Y80-0501
26U	1000	22	1194	CSZ-X-26Y00-0501
32U	600	22	1460	CSZ-X-32Y60-0501
32U	800	22	1460	CSZ-X-32Y80-0501
36U	600	22	1638	CSZ-X-36Y60-0501
36U	800	22	1638	CSZ-X-36Y80-0501
36U	1000	22	1638	CSZ-X-36Y00-0501
36U	1200	22	1638	CSZ-X-36Y20-0501
39U	800	22	1772	CSZ-X-39Y80-0501
39U	1000	22	1772	CSZ-X-39Y00-0501
42U	600	22	1905	CSZ-X-42Y60-0501
42U	800	22	1905	CSZ-X-42Y80-0501
42U	1000	22	1905	CSZ-X-42Y00-0501
42U	1100	22	1905	CSZ-X-42Y10-0501
42U	1200	22	1905	CSZ-X-42Y20-0501
47U	600	22	2127	CSZ-X-47Y60-0501
47U	800	22	2127	CSZ-X-47Y80-0501
47U	1000	22	2127	CSZ-X-47Y00-0501
47U	1100	22	2127	CSZ-X-47Y10-0501
47U	1200	22	2127	CSZ-X-47Y20-0501

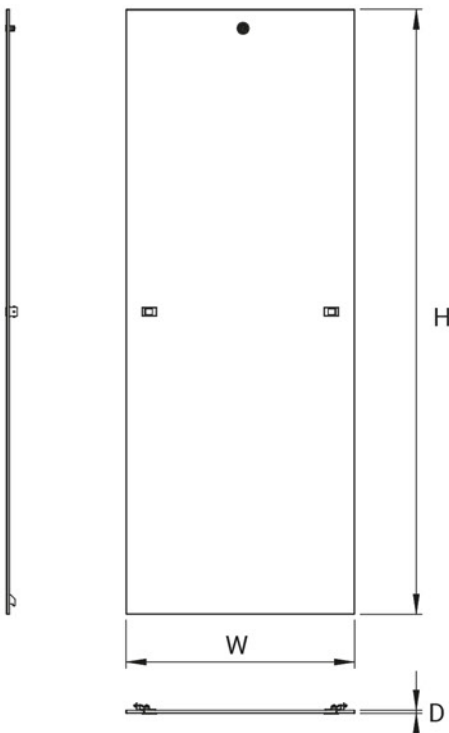

X (Color code): 7:RAL 7035 Light Grey, 9:RAL 9005 Black

# Inorax-ST Network Cabinet

## Rear Metal Solid Panel

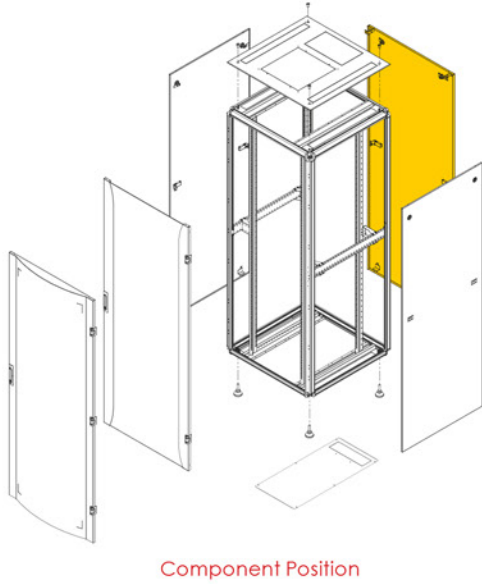

## Rear Metal Solid Panel Options

Material	1 mm Steel		Finish	Zinc-Plated		
H (U)	W (mm)	D (mm)	H (mm)	Weight kg	Part No	
16U	600	23	752	5.1	CSZ-X-166Y0-0901	
22U	600	23	1018	6,7	CSZ-X-226Y0-0901	
22U	800	23	1018	8,8	CSZ-X-228Y0-0901	
26U	600	23	1196	7,8	CSZ-X-266Y0-0901	
26U	800	23	1196	10,2	CSZ-X-268Y0-0901	
32U	600	23	1463	9,5	CSZ-X-326Y0-0901	
32U	800	23	1463	12,3	CSZ-X-328Y0-0901	
36U	600	23	1641	10,6	CSZ-X-366Y0-0901	
36U	800	23	1641	13,8	CSZ-X-368Y0-0901	
39U	800	23	1774	14,9	CSZ-X-398Y0-0901	
42U	600	23	1907	12,2	CSZ-X-426Y0-0901	
42U	800	23	1907	16,0	CSZ-X-428Y0-0901	
47U	600	23	2130	13,6	CSZ-X-476Y0-0901	
47U	800	23	2130	17,7	CSZ-X-478Y0-0901	

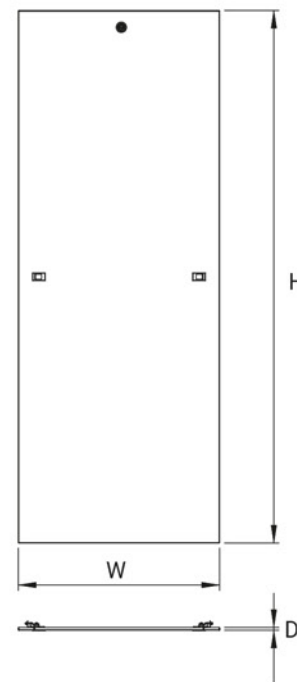

X (Color code): 7:RAL 7035 Light Grey, 9:RAL 9005 Black

# Inorax-ST Network Cabinet

## Single Door Options Metal Solid Door

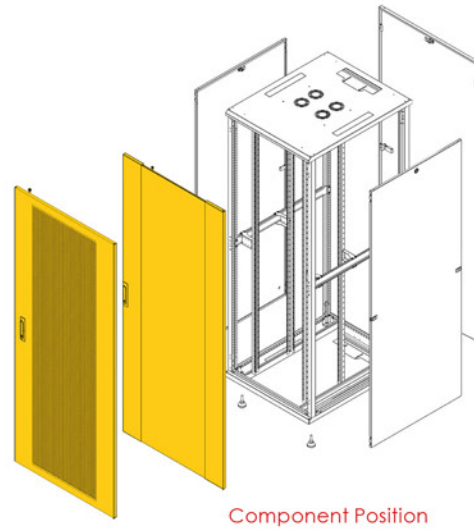
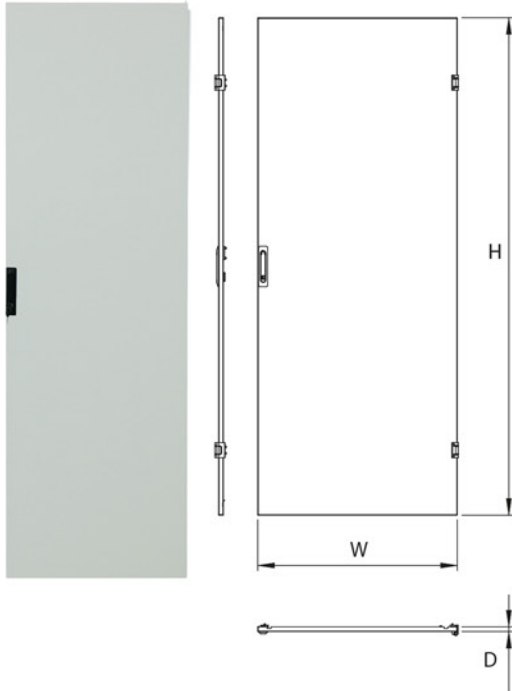

## Metal Solid Door Options

Material	1.2 mm Steel	Finish	Electrostatic Powder Paint
Color	RAL 7035 (Light Grey) and RAL 9005 (Black)		

H (U)	W (mm)	D (mm)	H (mm)	Weight kg	Part No
16U	600	22	749	6,87	CSZ-X-166Y0-0902
22U	600	22	1016	8,94	CSZ-X-226Y0-0902
22U	800	22	1016	11,26	CSZ-X-228Y0-0902
26U	600	22	1194	10,32	CSZ-X-266Y0-0902
26U	800	22	1194	12,97	CSZ-X-268Y0-0902
32U	600	22	1460	12,39	CSZ-X-326Y0-0902
32U	800	22	1460	15,54	CSZ-X-328Y0-0902
36U	600	22	1638	13,77	CSZ-X-366Y0-0902
36U	800	22	1638	17,26	CSZ-X-368Y0-0902
39U	800	22	1772	18,54	CSZ-X-398Y0-0902
42U	600	22	1905	15,84	CSZ-X-426Y0-0902
42U	800	22	1905	19,83	CSZ-X-428Y0-0902
47U	600	22	2127	17,56	CSZ-X-476Y0-0902
47U	800	22	2127	21,97	CSZ-X-478Y0-0902

## Glass Door

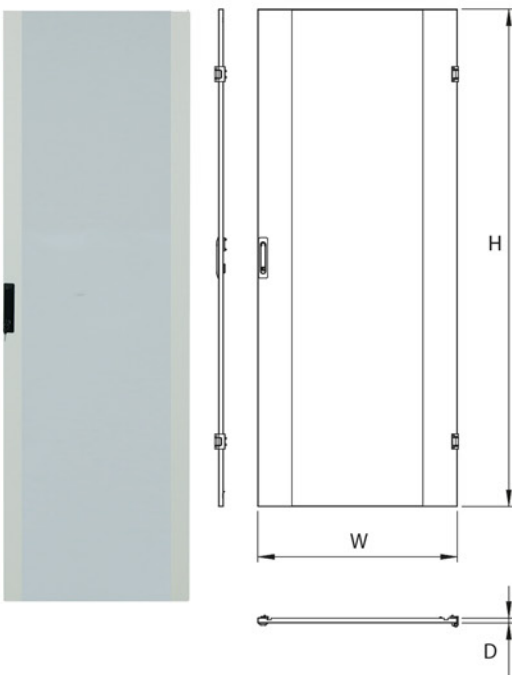

## Glass Door Options

Material	1.2 mm Steel	Finish	Electrostatic Powder Paint
Color	RAL 7035 (Light Grey) and RAL 9005 (Black)		

H (U)	W (mm)	D (mm)	H (mm)	Weight kg	Part No
16U	600	22	749	5,53	CSZ-X-166Y0-0903
22U	600	22	1016	7,42	CSZ-X-226Y0-0903
22U	800	22	1016	9,77	CSZ-X-228Y0-0903
26U	600	22	1194	8,68	CSZ-X-266Y0-0903
26U	800	22	1194	11,42	CSZ-X-268Y0-0903
32U	600	22	1460	10,56	CSZ-X-326Y0-0903
32U	800	22	1460	13,9	CSZ-X-328Y0-0903
36U	600	22	1638	11,82	CSZ-X-366Y0-0903
36U	800	22	1638	15,55	CSZ-X-368Y0-0903
39U	800	22	1772	16,79	CSZ-X-398Y0-0903
42U	600	22	1905	13,7	CSZ-X-426Y0-0903
42U	800	22	1905	18,02	CSZ-X-428Y0-0903
47U	600	22	2127	15,27	CSZ-X-476Y0-0903
47U	800	22	2127	20,09	CSZ-X-478Y0-0903

X (Color code): 7:RAL 7035 Light Grey, 9:RAL 9005 Black

# Inorax-ST Network Cabinet

## Perforated Flat Door

### Perforated Flat Door Options

<b>Material</b>	1.2 mm Steel	<b>Color</b>	RAL 7035 (Light Grey) and RAL 9005 (Black)
<b>Finish</b>	Electrostatic Powder Paint	<b>Perforation Rate</b>	65%

H (U)	W (mm)	D (mm)	H (mm)	Weight kg	Part No
26U	600	22	1194	7,81	CSZ-X-266Y0-0904
36U	600	22	1638	10,15	CSZ-X-366Y0-0904
39U	800	22	1772	14,02	CSZ-X-398Y0-0904
42U	600	22	1905	11,80	CSZ-X-426Y0-0904
42U	800	22	1905	15,17	CSZ-X-428Y0-0904
47U	600	22	2127	12,97	CSZ-X-476Y0-0904
47U	800	22	2127	16,69	CSZ-X-478Y0-0904

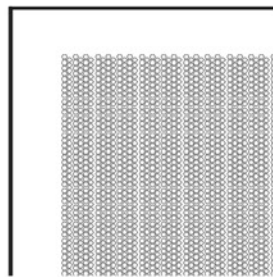

Perforation Detail

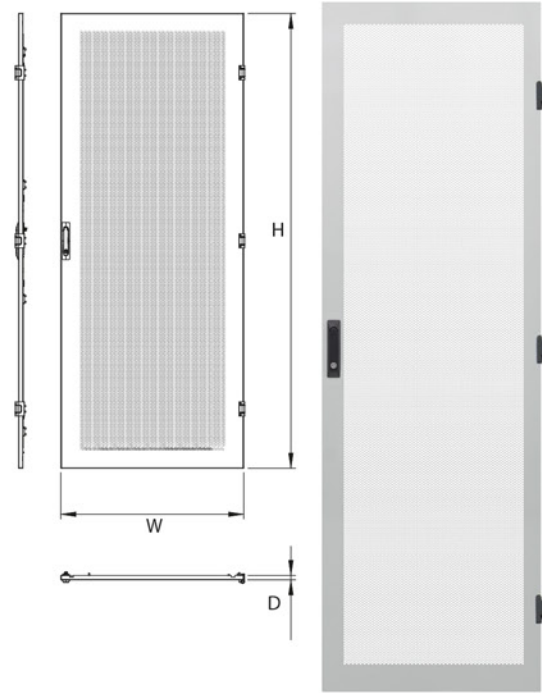

### High Perforation Rated Flat Door Options

<b>Material</b>	1.2 mm Steel	<b>Color</b>	RAL 7035 (Light Grey) and RAL 9005 (Black)
<b>Finish</b>	Electrostatic Powder Paint	<b>Perforation Rate</b>	80%

H (U)	W (mm)	D (mm)	H (mm)	Weight kg	Part No
26U	600	22	1194	7,51	CSZ-X-266Y0-0909
36U	600	22	1638	9,85	CSZ-X-366Y0-0909
39U	800	22	1772	13,72	CSZ-X-398Y0-0909
42U	600	22	1905	11,50	CSZ-X-426Y0-0909
42U	800	22	1905	14,87	CSZ-X-428Y0-0909
47U	600	22	2127	12,67	CSZ-X-476Y0-0909
47U	800	22	2127	16,39	CSZ-X-478Y0-0909

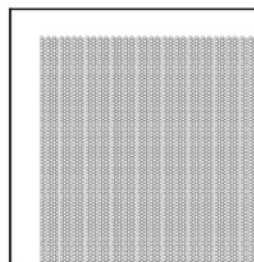

Perforation Detail

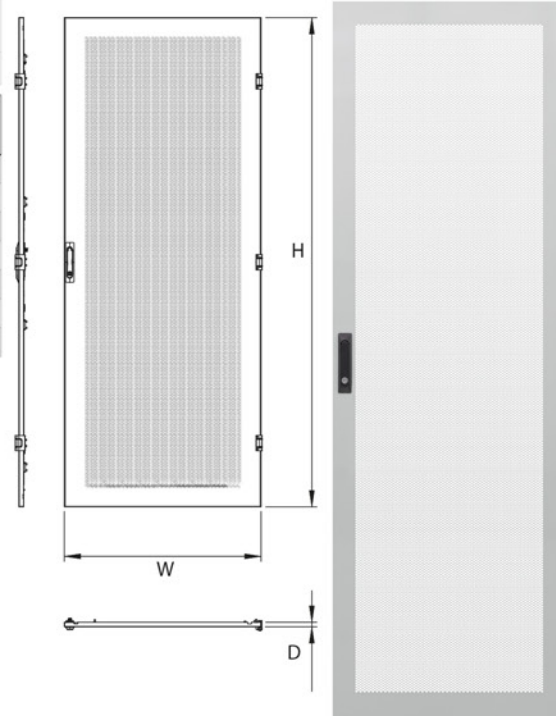

X (Color code): 7:RAL 7035 Light Grey, 9:RAL 9005 Black



# Inorax-ST Network Cabinet

## Double Door Options Double Perforated Door

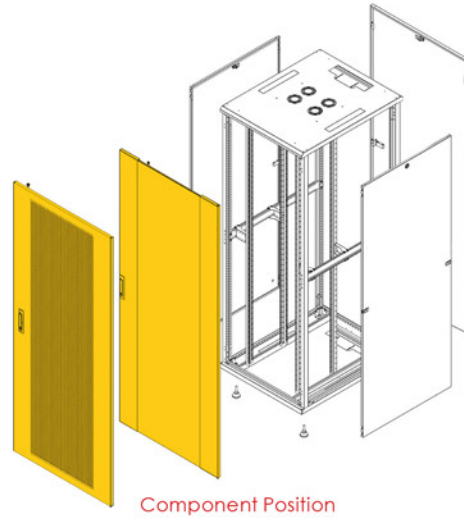
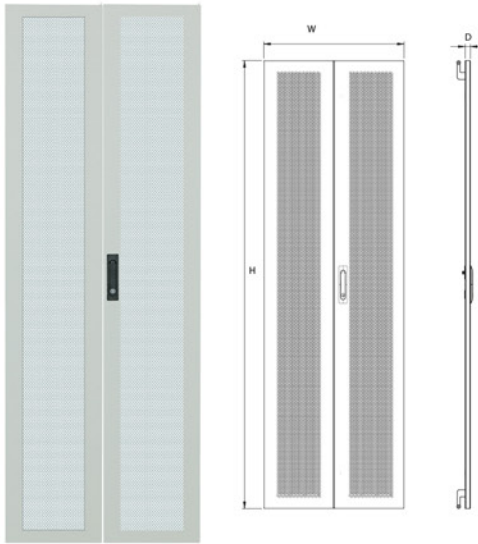

## Double Perforated Door Options

<b>Material</b>	1.2 mm Steel	<b>Color</b>	RAL 7035 (Light Grey) and RAL 9005 (Black)		
<b>Finish</b>	Electrostatic Powder Paint		<b>Perforation Rate</b>	65%	
<b>H (U)</b>	<b>W (mm)</b>	<b>D (mm)</b>	<b>H (mm)</b>	<b>Weight kg</b>	<b>Part No</b>
26U	600	22	1194	11,99	CSZ-X-266Y0-0908
36U	600	22	1638	15,70	CSZ-X-366Y0-0908
39U	800	22	1772	21,19	CSZ-X-398Y0-0908
42U	600	22	1905	18,16	CSZ-X-426Y0-0908
42U	800	22	1905	22,83	CSZ-X-428Y0-0908
47U	600	22	2127	20,01	CSZ-X-476Y0-0908
47U	800	22	2127	25,16	CSZ-X-478Y0-0908

## High Perforation Rated Double Door

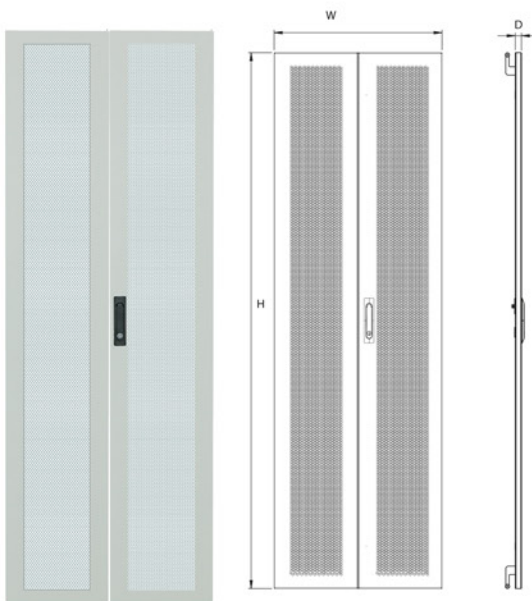

## High Perforation Rated Double Door Options

<b>Material</b>	1.2 mm Steel	<b>Color</b>	RAL 7035 (Light Grey) and RAL 9005 (Black)		
<b>Finish</b>	Electrostatic Powder Paint		<b>Perforation Rate</b>	80%	
<b>H (U)</b>	<b>W (mm)</b>	<b>D (mm)</b>	<b>H (mm)</b>	<b>Weight kg</b>	<b>Part No</b>
26U	600	22	1194	11,69	CSZ-X-266Y0-0911
36U	600	22	1638	15,40	CSZ-X-366Y0-0911
39U	800	22	1772	20,89	CSZ-X-398Y0-0911
42U	600	22	1905	17,86	CSZ-X-426Y0-0911
42U	800	22	1905	22,53	CSZ-X-428Y0-0911
47U	600	22	2127	19,71	CSZ-X-476Y0-0911
47U	800	22	2127	24,86	CSZ-X-478Y0-0911

X (Color code): 7:RAL 7035 Light Grey, 9:RAL 9005 Black



## Inorax-ST Network Cabinet

### Locking Device Systems

#### Multi Point Lock for Double Doors

Material	Steel, Polyamide
Packaging	1 piece in a box
Part No	CSZ-0-YYYY0-1005

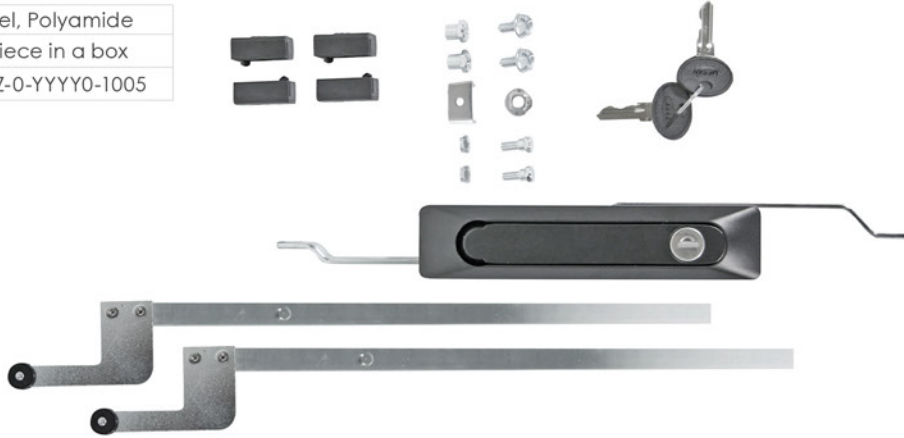

#### Four Point Lock for Single Curved Perforated Door

Material	Steel, Polyamide
Packaging	1 piece in a box
Part No	CSZ-0-YYYY0-1004



#### Three Point Lock for Single Perforated Door

Material	Steel, Polyamide
Packaging	1 piece in a box
Part No	CSZ-0-YYYY0-1006

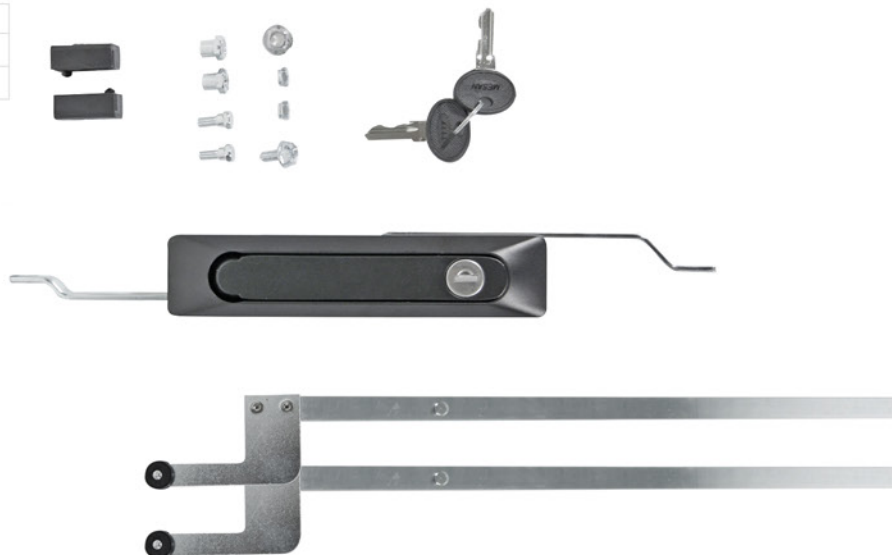

**Inorax-ST Network Cabinet**



**Single Point Lock**

Material	Polyamide
Packaging	1 piece in a box
Part No	CPZ-0-YYYY0-1003

**Cylindrical Lock for Side Panel**



Material	Zamak, Steel
Packaging	1 piece in a box
Part No	CPZ-0-YYYY0-1001

**Cylindrical Lock for Rear Metal Solid Panel**



Material	Zamak, Steel
Packaging	1 piece in a box
Part No	CPZ-0-YYYY0-1002